



ELECTRIC CHAIN HOIST SA TYPE 1 PHASE, 1 SPEED

Optional Overload Limit Device for the SA Hoists

Our new Torcon overload protection device is a slip clutch style. In the event of an overload, the device actuates and prevents the hoist from continuing to lift. This mechanism protects the hoist from damage.

- Single phase class B insulation with a short time duty of 25 minutes.
- Thermal protector - senses abnormal rise in temperatures within the motor and automatically shuts the motor down to prevent damage.

Optional Motorized Trolleys

- MTS series motorized trolley, single phase, for combination with the SA electric chain hoists. 1/4t - 1 ton only.
- Trolleys come with pivoting adapter for hook to hook type suspension or lug type suspension

Wiring - Simple Plug-In Type Connection

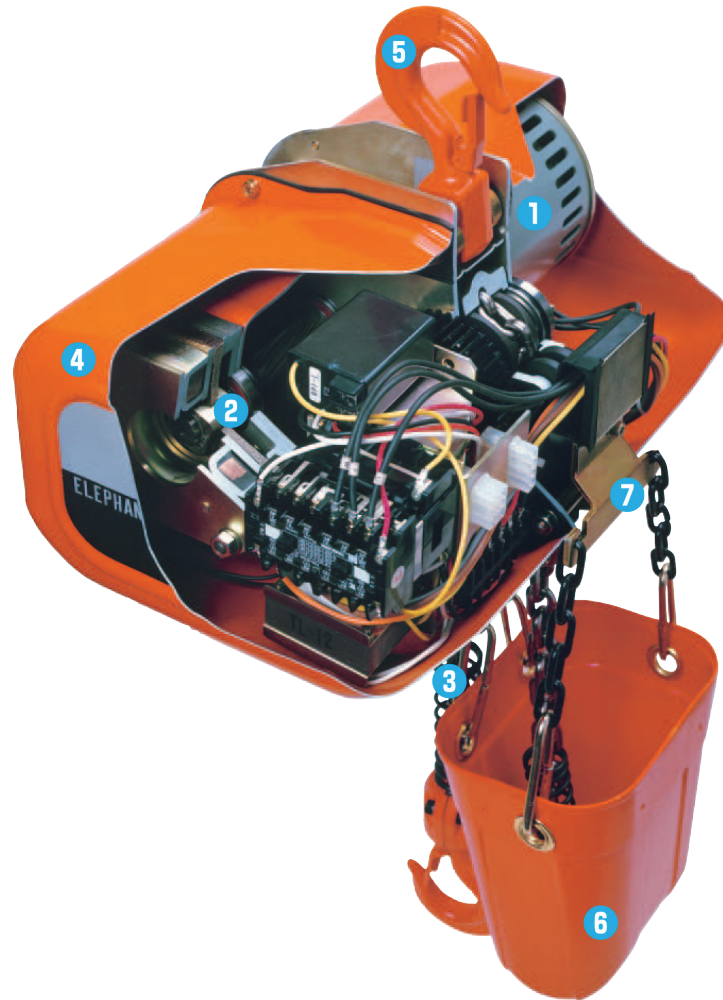

FEATURES OF SA/SAM

1 Tough, Heavy-Duty Motor

Elephant's unique design for a lower power consumption.

	Insulation class	Short time duty
SA	B	25 minutes

2 Reliable Electro-Magnetic DC Brake

3 Highly durable load chain manufactured in Japan by Elephant

4 Totally Enclosed Steel Plate Construction

5 Durable top and bottom hooks

Bottom hook with bearing smoothly swivels, 360°. In the event of an overload, the hook gradually elongates. This elongation serves as an indicator to the end user, making them aware of the overload.

6 Chain Bucket Hard plastic

7 Limit switch Standard feature

8 Ambient temperature range 14°-104° F

9 Ratings JIS/ISO M4, FEM 1AM, ASME H3 Motor, IP54 Hoist Protection, IP65 NEMA 4X Pendant Protection

Note: This model is not designed for excessive inching or jogging



SA TYPE HOOK SUSPENSION

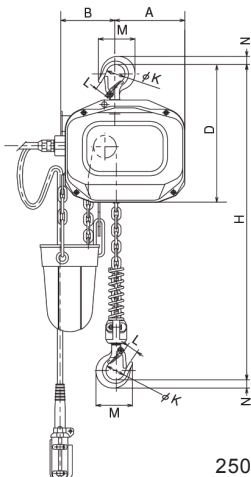

250kg~0.5t

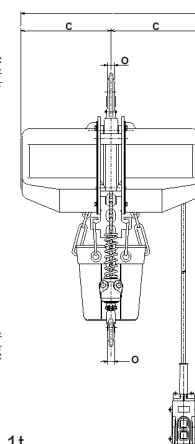
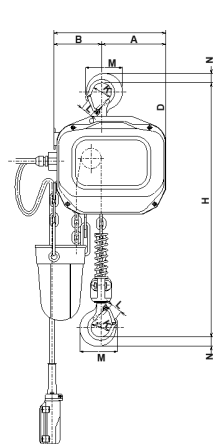
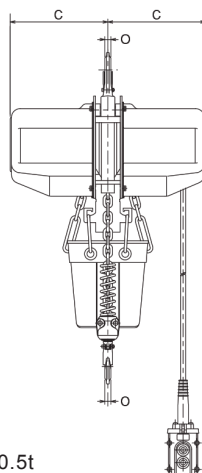

1t

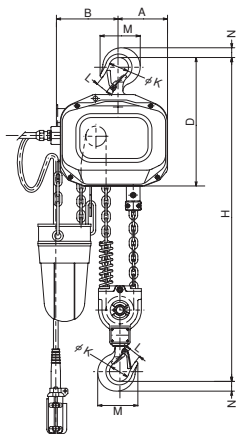

1t w - 2t

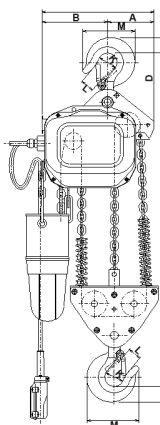
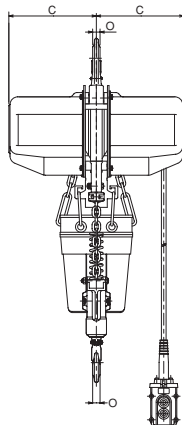

3t

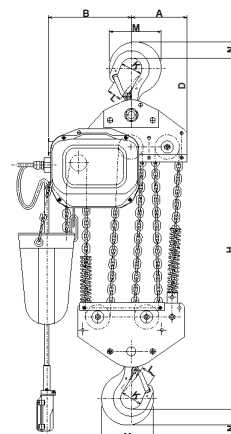
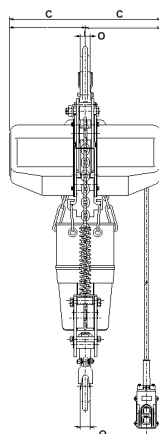

5t

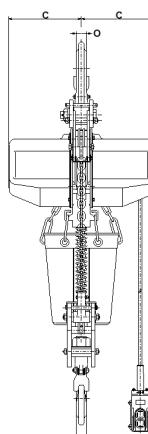

SPECIFICATIONS - SA TYPE HOOK SUSPENSION

Model	W.L.L. (lbs)	W.L.L. (mt)	Test Load (mt)	Standard Lift (ft)	Standard Push Button Cord Length (ft)	Load Chain Dia. X Number of Falls	Lifting Motor Output (H.P.)	Lifting Speed (ft/min)		Min. Distance H (in)	Net Weight
								50Hz	60Hz		
SA-0.25	550	250kg	312.5 kg	10	8	6.3 x 1	0.61	23	27.5	21.85	95
SA-0.5	1100	0.5	0.625	10	8	6.3 x 1	0.61	11.5	13.5	21.85	95
SA-1W	2200	1	1.25	10	8	6.3 x 2	0.61	6	7	26.38	102
SA-1S	2200	1	1.25	10	8	7.1 x 1	1.21	9	10	23.2	136
SA-2	4400	2	2.5	10	8	7.1 x 2	1.21	4	5	29.33	152
SA-3	6600	3	3.75	10	8	7.1 x 3	1.21	3	3.3	33.07	191
SA-5	11000	5	6.25	10	8	7.1 x 5	1.21	1.7	2	38.2	248

DIMENSIONS (IN.) - SA TYPE HOOK SUSPENSION

W.L.L. (lbs)	W.L.L. (mt)	A	B	C	D	K	L	M	N	O
550	250kg	6.34	4.88	8.82	12.24	1.69	1.04	3.31	0.75	0.55
1100	0.5	6.34	4.88	8.82	12.24	1.69	1.04	3.31	0.75	0.55
2200	1	5	6.22	8.82	12.97	1.97	1.22	4.06	0.98	0.75
2200	1	6.7	5.04	9.4	5.04	1.96	1.22	3.86	0.98	0.75
4400	2	5.24	6.5	9.4	6.5	2.56	1.5	5.33	1.38	1.02
6600	3	5.82	8.19	9.4	16.8	2.36	1.7	6.5	1.93	1.26
11000	5	7.2	10.74	9.4	19.2	2.76	1.85	6.69	2.08	1.4

*Contact Factory For Additional Information





SAM TYPE 1 SPEED HOIST, 1 SPEED MOTORIZED TROLLEY

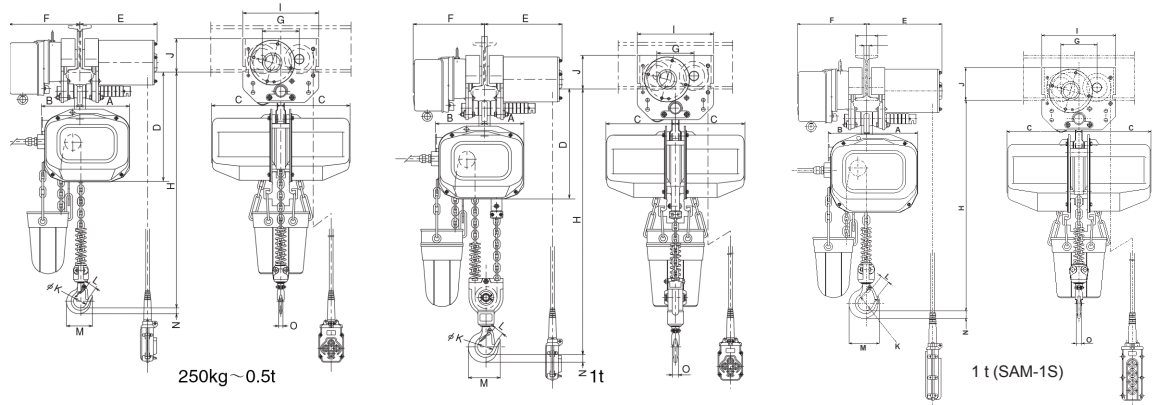

SPECIFICATIONS - SAM TYPE (SINGLE SPEED) ELECTRIC CHAIN HOIST WITH ELECTRIC TROLLEY

Model	W.L.L. (lbs)	W.L.L. (mt)	Test Load (mt)	Standard Lift (ft)	Traversing Motor Output (H.P.)	Traversing Speed (ft/min)		Min. Distance H (in) Hook : Lug	Traversing I-Beam Width (in)	Trolley Min. Radius (in)	Net Weight (lbs)
						50Hz	60Hz				
SAM-0.25	550	250kg	312.5 kg	10	0.41	32	39	27.36 (23.62)	2.95 - 5.91	43.31	163
SAM-0.5	1100	0.5	0.625	10		32	39	27.36 (23.62)			
SAM-1	2200	1	1.25	10		32	39	31.89 (27.76)			
SAM-1S	2200	1	1.25	10		32	39	28.74(24.61)			

DIMENSIONS (IN.) - SAM TYPE (SINGLE SPEED) ELECTRIC CHAIN HOIST WITH ELECTRIC TROLLEY

W.L.L. (lbs)	W.L.L. (mt)	A	B	C	D	E	F	G	I	J	K	L	M	N	O	P (Dia. of Wheel)
550	250kg	6.34	4.88	8.82	17.97	9.88	8.6	4.72	9.69	4.49	1.69	1.04	3.31	0.75	0.55	2.68
1100	0.5	6.34	4.88	8.82	17.97	9.88	8.6	4.72	9.69	4.49	1.69	1.04	3.31	0.75	0.55	2.68
2200	1	5	6.22	8.82	20.91	9.88	8.6	4.72	9.69	4.49	1.97	1.22	4.06	0.98	0.75	2.68
2200S	1	6.69	5.04	9.41	19.25	9.88	8.6	4.72	9.69	4.49	1.97	1.22	4.06	0.98	0.75	2.68

EMERGENCY STOP BUTTON

Standard Feature On Single Phase Units



CABLE HANGER

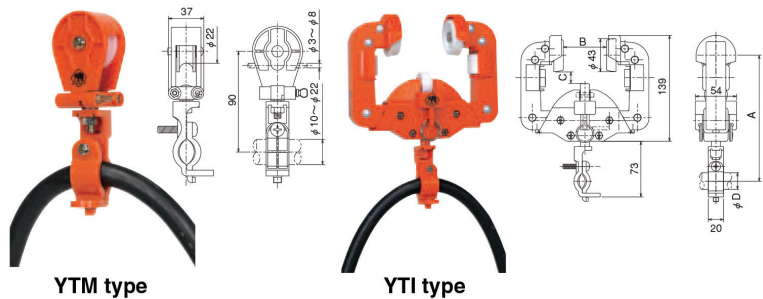

DIMENSIONS (IN.) - CABLE HANGER

Model	I-Beam Width	A	B	C	D (Cable Dia.)
YTI-100	2.95	6.54	1.26	0.59	0.39 - 0.87
	3.94	6.54	2.24	0.59	0.39 - 0.87
YTI-150	4.92	6.54	3.23	0.98	0.39 - 0.87
	5.91	6.54	4.21	0.98	0.39 - 0.87

